

TOPPING MOWER

Operation Manual



CONTENTS

		GENERAL SAFETY	
Chapter 1	Introduction.....		2
Chapter 2	Safety Rules.....		2
	2.1 General safety		
	2.2 Equipment Safety Guideline		
	2.3 Safety Training		
	2.4 Safety Sign		
	2.5 Operating Safety		
	2.6 Storage Safety		
	2.7 Maintenance Safety		
Chapter 3	Operation.....		8
	3.1 Machine Components		
	3.2 Machine Break-in		
	3.3 Pre-Operation Checklist		
	3.4 Equipment Matching		
	3.5 Driveline Dimension		
	3.6 Driveline Dimension		
	3.7 Attaching/Unhooking		
	3.8 Field Operation		
	3.9 Storage		
Chapter 4	Service and Maintenance		15
	4.1 Service		
	4.2 Maintenance		
Chapter 5	Troubles and Trouble-shooting.....		17
Chapter 6	Assembly		18
Chapter 7	Specifications.....		18
	7.1 Mechanical		
	7.2 Bolt Torque		
Chapter 8	Parts List		20

Chapter 1. INTRODUCTION

Thank you for your choice of our Slasher to complement your mowing operation. This equipment has been designed and manufactured to meet the needs of a discriminating buyer for the efficient cutting of grass.

Safe, efficient and trouble free operation of your Slasher requires that you and anyone else who will be operating or maintaining the machine, read and understand the Safety, Operation, Maintenance and Trouble Shooting information contained within the Operator's Manual. Use the Contents as a guide to locate required information.

Keep this manual handy for frequent reference and to pass on to new operators or owners. Call your dealer or distributor if you need assistance, information or additional copies of the manuals.

OPERATOR ORIENTATION – The directions left, right, front and rear, as mentioned throughout this manual, are as seen from the driver's seat and facing in the direction of travel.

Chapter 2. SAFETY RULES

Read these safety rules attentively and strictly follow suggested precautions to avoid any potential danger and safeguard your health and personal safety.

YOU are responsible for the SAFE operation and maintenance of your Slasher. YOU must ensure that you and anyone else who is going to operate, maintain or work around the Slasher be familiar with the operating and maintenance procedures and related SAFETY information contained in this manual. This manual will take you step-by-step through your working day and alerts you to all good safety practices that should be adhered to while operating the Slasher.

Remember, YOU are the key to safety. Good safety practices not only protect you but also the people around you. Make these practices a working part of your safety program. Be certain that EVERYONE operating this equipment is familiar with the recommended operating and maintenance procedures and follows all the safety precautions. Most accidents can be prevented. Do not risk injury of death by ignoring good safety practices.

- . Slasher owners must give operating instructions to operators or employees before allowing them to operate the machine.
- . The most important safety feature on this equipment is a SAFE operator. It is the operator's responsibility to read and understand ALL Safety and Operating instructions in the manual and to follow these. All accidents can be avoided.
- . A person who has not read and understood all operating and safety instructions is not qualified to operate the machine. An untrained operator exposes himself and bystanders to possible serious injury or death.
- . Do not modify the equipment in any way. Unauthorized modification may impair the function and/or safety and could affect the life of the equipment.
- . Think SAFETY! Work SAFELY!

The purpose of this handbook is to familiarize the operator with the operation and regular servicing of the machine. Remember that the time spent on maintenance extends the life of your tractor.

2.1 GENERAL SAFETY

1. Read the operator's Manual and all safety signs carefully before operating, maintaining, adjusting or unplugging the Slasher.
2. Have a first-aid kit available for use should the need arise and know how to use it.
3. Have a fire extinguisher available for use should the need arise and know how to use it.
4. Wear appropriate protective gear. This list includes but is not limited to:
 - A hard hat
 - Protective shoes with slip resistant soles
 - Protective goggles, glasses or face shield
 - Heavy gloves
 - Protective clothing
5. Install and secure all guards before starting
6. Do not allow riders.
7. Wear suitable ear protection for prolonged exposure to excessive noise.
8. Place all controls in neutral, stop tractor engine, set park brake, remove ignition key and wait for all moving parts to stop before servicing, adjusting, repairing or unplugging.
9. Clear the area of people, especially small children, before starting.
10. Review safety related items annually with all personnel who will operate or maintain the Slashers.
11. Do not operate tractor if you feel unwell or physically unfit, in which case you should stop working.

2.2 EQUIPMENT SAFETY GUIDELINES

1. Safety of the operator and bystanders is one of the main concerns in designing and developing a machine. However, every year many accidents occur which could have been avoided by a few seconds of thought and a more careful approach to handling equipment. You, the operator, can avoid many accidents section. To avoid personal injury or death, study the following precautions and insist those working with you, or for you, follow them.
2. **In order to provide a better view, certain photographs or illustrations in this manual may show an assembly with a safety shield removed. However, equipment should never be operated in this condition.** Keep all shields in place. If shield removal becomes necessary for repairs, replace the shield prior to use.
3. Replace any safety sign or instruction sign that is not readable or is missing. **Location of such safety signs is indicated in this manual.**
4. Never use alcoholic beverages or drugs that can hinder alertness or coordination while operating this equipment. Consult your doctor about operating this machine while taking prescription medications.
5. Under no circumstances should young children be allowed to work with this equipment. Do not allow persons to operate or assemble this unit until they have read this manual and have developed a thorough understanding of the safety precautions and of how it works. **Review the safety instructions with all users annually.**
6. This equipment is dangerous to children and persons unfamiliar with its operation. The operator should be a responsible, properly trained and physically able person familiar with farm machinery and trained in this equipment's. If the elderly are assisting with farm work, their physical limitations need to be recognized and accommodated.
7. Use a tractor equipped with a Roll Over Protective Structure (ROPS). Always wear your seat belt.

Serious injury or even death could result from falling off the tractor – particularly during a turnover when the operator could be pinned under the ROPS or the tractor.

8. Never exceed the limits of a piece of machinery. If its ability to do a job, or to do so safely, is in question – **DON'T TRY IT.**
9. Clear working area of stones, branches or hidden obstacles that might be hooked or snagged, causing injury or damage.
10. Operate only in daylight or good artificial light.
11. Do not modify the equipment in any way. Unauthorized modifications result in serious injury or death and may impair the function and life of the equipment.
12. In addition to the design and configuration of this implement, including Safety Signs and Safety Equipment, hazard control and accident prevention are dependent upon the awareness, concern, personnel involved in the operation, transport, maintenance, and storage of the machine. **Refer also to Safety Messages and operation instruction in each of the appropriate sections of the Tractor and machine Manuals. Pay close attention to the Safety Signs affixed to the Tractor and the machine.**

2.3 SAFETY TRAINING

1. Safety is a primary concern in the design and manufacture of our products. Unfortunately, our efforts to provide safe equipment can be wiped out by a single careless act of an operator or bystander.
2. In addition to the design and configuration of equipment, hazard control and accident prevention are dependent upon the awareness, concern, prudence and proper training of personnel involved in the operation, transport, maintenance and storage of this equipment.
3. It has been said, “The best safety feature is an informed, careful operator.” We ask you to be that kind of an operator. It is the operator’s responsibility to read and understand ALL Safety and Operating instructions in the manual and to follow these. Accidents can be avoided.
4. Working with unfamiliar equipment can lead to careless injuries. Read this manual, and the manual for your tractor, before assembly or operating, to acquaint yourself with the machines. If this machine is used by any person other than yourself, or is loaned or rented, it is the machine owner’s responsibility to make certain that the operator, prior to operating:
 - a. Reads and understands the operator’s manuals.
 - b. Be instructed in safe and proper use.
5. Know your controls and how to stop tractor, engine, and machine quickly in an emergency. Read this manual and the one provided with your tractor.
6. A person who has not read and understood all operating and safety instructions is not qualified to operate the machine. An untrained operator exposes himself and bystanders to possible serious injury or death. Train all new personnel and review instructions frequently with existing workers. Be certain only a properly trained and physically able person will operate the machine.

2.4 SAFETY SIGNS

1. Keep safety signs clean and legible at all times.
2. Replace safety signs that are missing or have become illegible.
3. Replaced parts that displayed a safety sign should also display the current sign,
4. Safety signs are available from your authorized Distributor or Dealer Parts Department or the factory.

Safety Signs locations

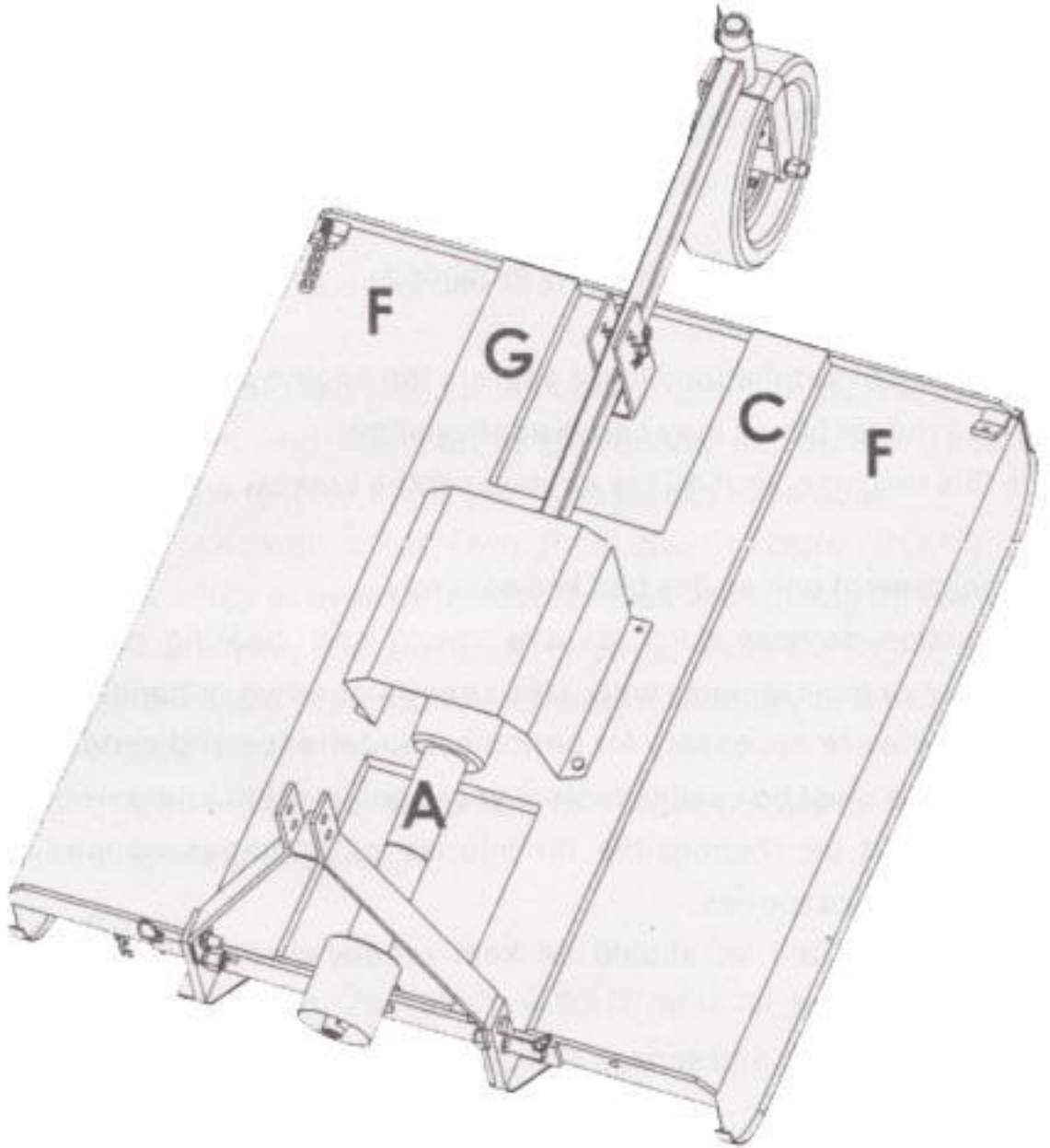



2.5 OPERATING SAFETY

1. Read and understand the Operator's Manual and all safety signs before operating, servicing, adjusting, repairing or unplugging.
2. Do not allow riders.
3. Install and secure all guards and shields before starting or operating.
4. Keep hands, feet, hair and clothing away from moving parts.
5. Place all controls in neutral, stop tractor engine, set park brake, remove ignition key and wait for all moving parts to stop before servicing, adjusting, repairing or unplugging.
6. Place all tractor and machine controls in neutral before starting.
7. Never start or operate machine unless sitting on tractor seat.
8. Clear the area of bystanders, especially small children, before starting
9. Stay away from PTO shaft and machine when engaging PTO. Keep others away.
10. Clean reflectors, SMV and lights before transporting.
11. Use hazard flashers on tractor when transporting.
12. Do not put hands or feet under machine while tractor engine or machine is running.
13. Do not operate Slasher in the raised position.
14. Objects can be thrown out from under machine with sufficient force to severely injure people. Stay away from machine when it is running. Keep others away.
15. Always know what you are cutting. Never operate cutter in an area that has hidden obstacles. Remove sticks, stones, wire or other objects from working area before starting.
16. Review safety instructions with all operators annually.

2.6 STORAGE SAFETY

1. Store the machine in an area away from human activity.
2. Do not permit children to play on or around the stored machine.
3. Store the machine in a dry, level area. Support the frame with planks if required.

2.7 MAINTENANCE SAFETY

1. Good maintenance is your responsibility. Poor maintenance is an invitation to trouble.
2. Follow good shop practices.
 - Keep service area clean and dry.
 - Be sure electrical outlets and tools are properly grounded.
 - Use adequate light for the job at hand.
3. Make sure there is plenty of ventilation. Never operate the engine of the towing vehicle in a closed building. The exhaust fumes may cause asphyxiation.
4. Before working on this machine, shut off the engine, set the brakes, and remove the ignition key.
5. Never work under equipment unless it is blocked securely.
6. Use personal protection devices such as eye, hand and hearing protectors, when performing any service or maintenance work. Use heavy gloves when handling cutter blades.
7. When replacement parts are necessary for periodic maintenance and servicing, genuine factory replacement parts must be used to restore your equipment to original specifications. The manufacturer will not be responsible for injuries or damages caused by use of unapproved parts and/or accessories.
8. A tire extinguisher and first aid kit should be kept readily accessible while performing maintenance

on this equipment.

9. Periodically tighten all bolts, nuts and screws and check that all cotter pins are properly installed to ensure unit is in a safe condition.
10. When completing a maintenance or service function, make sure all safety shields and devices are installed before placing machine in service.

Chapter 3. OPERATION

The Slasher is designed to cut a variety of grasses and other ground covers. Rotational power to the blades is provided by the tractor PTO. Be familiar with the machine before starting.

In addition to the design and configuration of equipment, hazard control and accident prevention are dependent upon the awareness, concern, prudence and proper training of personnel involved in the operation, transport, maintenance and storage of equipment. It is the responsibility of the owner or operator to read this manual and to train all other operators before they start working with the machine. Follow all safety instructions exactly.

Safety is every one's business. By following recommended procedures, a safe working environment is provided for the operator, bystanders and the area around the worksite. Untrained operators are not qualified to operate the machine.

Many features incorporated into this machine are the result of suggestions made by customers like you. Read this manual carefully to learn how to operate the machine safely and how to set it to provide maximum field efficiency. By following the operating instructions in conjunction with a good maintenance program, your Slasher will provide many years of trouble-free service.

3.1 MACHINE COMPONENTS

The Slasher consists of one large rotating plate with free-swinging steel blades attached to it. The blades cut the grass while traveling over the working area. Rotational power to the plate is provided by the tractor PTO through the gearbox in the center of the machine.

Remove the stump deflector plate from the gearbox output shaft to access the blade anchor bolts.

The Slasher attaches to the 3 point hitch on the tractor.

3.2 MACHINE BREAK-IN

Although there are no operational restrictions on the Slasher when used for the first time, it is recommended that the following mechanical items be checked:

A. After operating for 1/2 hour or after completing 2 acres:

1. Check all nuts, bolts and other fasteners. Tighten to their specified torque level.
2. Tighten blade bolts to their specified torque levels.
3. Check that the blades are in good condition and swing freely.
4. Check the oil level in the gear box. Add as required.
5. Check that the PTO driveline shield turns freely.
6. Lubricate all grease points.

B. After operating for 5 hours and 10 hours:

1. Repeat items 1 to 5 of Section A.
2. Then go to the regular service schedule as defined in Section 4.

3.3 PRE-OPERATION CHECKLIST

Efficient and safe operation of the Slasher requires that each operator reads and understands the operating procedures and all related safety precautions outlined in this section. A pre-operation checklist is provided for the operator. It is important for both the personal safety and maintaining the good mechanical condition of the Slasher that this checklist is followed.

Before operating the machine and each time thereafter, the following areas should be checked off:

1. Lubricate the machine per the schedule outlined in Section 4 Service and Maintenance.
2. Use only an agricultural **tractor of horsepower within limits of the machine specified in Table 1.**
3. Check that the machine is properly attached to the tractor. Be sure retainers are used on the mounting pins.
4. Be sure extra weights are mounted on the front of the tractor.
5. Check the oil level in the gearbox. Add as required.
6. Check that the PTO driveline turns freely and that the driveline can telescope easily.
7. Check the blades. Be sure they are not damaged or broken and swing freely in their mount. Repair or replace as required.
8. Check the blade bolts. Tighten to their specified torque.
9. Check for entangled material in all rotating parts. Remove this material.
10. Install and secure all guards, doors and covers before starting.

3.4 EQUIPMENT MATCHING

To insure the safe and reliable operation of the Slasher, it is necessary to use a tractor with the correct specifications. Use the following list as a guide in selecting a tractor to use on the machine.

1. **Horsepower:**
The power requirements range from **55hp for light cutting in level terrain up to 80 hp** in heavy cutting in rough terrain. Use a tractor appropriate for your conditions.
2. **Front End Weights:**
It is recommended that tractor be equipped with front-end weights to provide extra stability. This is particularly important if using **front-wheel assist tractor.**
3. **3 Point Hitch:**
The Slasher is equipped with a **category II** 3 point hitch. Be sure the tractor 3 point hitch is in the proper configuration.

Install the lift arm stabilizer or shorten the stop chains to place the arms into the non-sway configuration. Refer to the tractor manual for details.
4. **Load Sensing Hydraulics:**
The operator should set the tractor hydraulic system to provide “float” on the 3 point hitch. Refer to the tractor manual for details.

The float feature will allow the machine to follow the ground contours during operation.
5. **PTO Shaft:**

The tractor must have a **1 3/8 inch 6 spline 540 RPM PTO shaft** to fit the the driveline shaft supplied with the machine. Do not use shaft adapters or operate at any other speed.

It is not recommended that a tractor with variable speed PTO's be used on the Slasher Operating at speeds faster than 540 RPM will overload the cutting components and lead to early failures.

3.5 DRIVELINE DIMENSION

A PTO driveline is supplied with the machine. To accommodate the variety of 3 point hitch geometry available today, the driveline can be too long for some machines or too short for others, It is very important that the driveline be free to telescope but not bottom out when going through its working range, If the driveline bottoms out, the bearings on both the slasher and tractor PTO shaft will be overloaded and fail in a short time.

To determine the proper length of the driveline, follow this procedure:

1. Attach the Slasher to the tractor (see Section 3.7) but do not attach the driveline.
2. Raise the machine until the input shaft is level with the tractor PTO shaft.
3. Measure the dimension (A) between the locking groove on the tractor PTO shaft and the groove on the Slasher input shaft.
4. Measure the same dimensions (B) on the compressed driveline. If the compressed driveline dimension exceeds the machine dimension, the driveline will have to be cut or exchanged.

If the machine dimension is greater than the fully extended length (6 shorter than fully extended), then a longer driveshaft should be purchased from your dealer.

5. Subtract the Machine dimension (A) from the uncut driveline dimension or (B-A). This dimension determines how much too long the driveline is.
6. Pull the driveline apart and measure the dimension determined in step 4 on the female end. Add another inch (25 mm) to the cut off segment.
7. Use a hacksaw to cut the dimension from the female end of the separated shaft. Cut both the plastic tube and the metal core.
8. Use a file to remove the burrs from the edged that were cut.
9. Assemble the two ends of the shaft.
10. On some drive shafts, the male end is as long as the female end. On others, the male end is considerably shorter.

If the compressed length is not correct, you may need to shorten the male end of the driveline. Follow instructions outlined in 1 to 4.

11. Make sure that the shaft can telescope freely. If it does not, separate the two parts and inspect for burrs or cuttings on the shaft ends. Be sure it telescopes freely before installing.
12. Make sure the plastic covering shield is free to rotate on the shaft before installing on the machine.
13. Lubricate male end of shaft.

3.6 ATTACHING/UNHOOKING

The Slasher should always be located on a level, dry area that is free of debris and other foreign objects. When attaching the machine to a tractor, follow this procedure:

1. Be sure the tractor 3 point hitch is in the **Category I** configuration and the lift arms are in the non-sway configuration (see tractor manual).
2. Be sure that balance weights are added on the front of the tractor.

3. Attach the PTO driveline to the Slasher.
4. While backing up, align the lift arm balls with the mounting pins on the Slasher.

Note: It may be necessary to add weight to the 3 point hitch to lower the lift arms.
5. Stop tractor, set park brake, remove ignition key and wait for all moving parts to stop before dismounting.
6. Align the left lower link arm with the mounting pin.
7. Slide the ball over the pin and install the retainer.
8. Use the screw jack on the right lift arm to align the ball with the pin.
9. Slide the ball over the mounting pin and install the retainer.
10. Level the frame and lift arms using the screw jack.
11. Attach the PTO driveline.
 - a. Check that the driveline telescopes easily and that the shield rotates freely.

Important: Be sure that the driveline does not bottom out when going through its working angles (Refer to Section 3.5).
 - b. Attach the driveline to the tractor by retracting the locking pin, slide the yoke over the shaft and push on the yoke until the lock pin clicks into position. Pull on the yoke to be sure it is locked in position.
12. Remove retainer and pin from the mast.
13. Align top link using the turnbuckle.
14. Insert pin and install retainer.
15. Set the mast using the turnbuckle to place the mounting pin at the front of its slot.
16. Use the 3 point hitch to raise the machine.
17. Reverse the above procedure when unhooking from the tractor.

3.7 FIELD OPERATION

This Slasher is designed with the inherent flexibility of operating well in almost any kind of grass and terrain conditions. However the operator has the responsibility of being familiar with all operating and safety procedures and following them.

1. Review and follow the **Pre-Operation Check-list**.
2. Attach the tractor to the machine (see Section 3.6).
3. Before going to the cutting area review Section 3.7 Transporting.
4. Pull into field and stop in a level area.
5. Lower into working position.
6. Set the machine:
 - a. Level the frame:
 - i. Use the screw jack on the right lift arm to level the frame from side-to-side.
 - ii. Use the turnbuckle on the top link to place the pin at the front of its slot. This will allow the machine to follow the contour of the ground.
 - iii. Set the 3 point hitch so deck is 25 to 50 mm higher at the rear of the deck than the front.
 - b. Height:

Use the turnbuckles on the trailing wheel frame to set the height of the deck. Adjust them evenly.

c. 3 Point Hitch

Place the 3 point into its “float” operating mode to allow the machine and the hitch to move up and down.

7. Align the unit with the working area.

8. Starting machine:

- a. Run the engine at low idle.
- b. Slowly engage the PTO control to start the machine.
- c. Slowly bring the engine to the rated PTO speed. Never exceed rated speed.
- d. Lower the machine to the ground and proceed down the field.

9. Stopping machine:

- a. Slowly decrease engine speed to low idle.

DANGER: Never operate Slasher in the raised position.

- b. Disengage PTO clutch slowly.

WARNING: Place all controls in neutral, lower machine, stop engine, set park, remove ignition key and wait for all moving parts to stop before dismounting.

10. Ground speed:

Travel speed can vary between 3 and 8 mph (5 and 13 kph) depending on the grass and terrain conditions. It is the responsibility of the operator to note the condition of the job being done and set the speed to obtain a quality cutting job and maintain control of the machine.

The speed can be increased if a good job is being done.

Decrease speed if you are producing a ragged cut or leaving patches uncut.

11. Operating hints:

- a. Although it is best to cut when it is dry, the Slasher works well in wet conditions as well. However, the operator will have to travel slower to do the same quality cutting. It will also be necessary to clean the machine more frequently to prevent caking and clogging of the blade area.
- b. Set the upper link at the front of its slot when level to prevent the driveline from hitting the deck when lifting.
- c. The Slasher should always be operated at the rated speed of 540 RPM. The cutting action is generated by the speed of the blade tip. When the speed drops below a certain rate (slowing of the input speed or RPM), the blades start to tear the material rather than cut it and will give a “ragged” looking cut.
- d. Vary ground speed by changing gears in the tractor transmission rather than changing the throttle setting. Forward travel speeds can range from 3 to 8 mph (5 to 13 km/h) or more depending on the type of terrain, grass or crop cover length, moisture level and power available.
- e. If the crop or grass is tall, cut it twice to obtain the best results. This allows the unit to cut less material on each pass.
- f. When cutting a new area for the first time, always set the mower to cut high to clear unknown obstructions. If none are found, the cutter can be run lower for the second pass.
- g. Never cut grass shorter than recommended for your weather conditions. Short grass is less able to withstand hot and dry condition. It is better for it to be cut oftener at a longer length than to cut it

too short.

- h. The blades will need sharpening when you see that the grass has not been cut evenly or it looks like the grass has been ripped off.
- i. The dished shape of rotating plate under the deck acts as a “stump jumper”. The concave shape allows the machine to go over stumps, rocks and other obstacles while operating.
- j. Always reduce ground speed when cutting around obstructions or in close quarters.
- k. The Slasher should always be operated with its trailing wheel riding on the ground and not normally lifted for turns or corners unless the ground is very rough or rutted. If lifted, it should be dropped back on the ground as soon as the maneuvering or rough terrain is past.
- l. The Slasher has two blades under its frame that are turning at a high rate of speed. With this speed, the blades can pick up objects on the ground and expel them out from under the frame or out the discharge areas.

WARNING: The rotating blades can pick up objects and expel them at a high rate of speed. These projectiles can be a hazard to the people and property. Never operate Slasher when there are bystanders, especially children around. Use extra care when operating in populated or congested areas.

3.8 TRANSPORTING

When transporting the machine, review and follow these instructions:

- 1. Be sure that the machine is securely attached to the tractor and all retainer pins are installed.
- 2. Be sure you have installed extra weights on the front of the tractor.
- 3. Clean the SMW emblem, lights and reflectors and be sure they are working.
- 4. Be sure you are in compliance with all applicable lighting and marking regulations when transporting.
- 5. Be sure your machine can clearly be seen by overtaking and oncoming traffic.
- 6. Do not allow riders.
- 7. Always use hazard flashers on the tractor when transporting.
- 8. Use pilot vehicles front and rear when transporting during times of limited visibility.

3.9 STORAGE

After the season’s use, the machine should be thoroughly inspected and prepared for storage. Repair or replace any worn or damaged components to prevent any unnecessary down time at the start of next season. To insure a long, trouble free life, this procedure should be followed when preparing the unit for storage:

- 1. Thoroughly wash the machine using a pressure washer to remove all dirt, mud, debris and residue.
- 2. Inspect the blades and rotor for damage or entangled material. Repair or replace damaged parts. Remove all entangled material.
- 3. Lubricate all grease fittings. Make sure that all grease cavities have been filled with grease to remove any water residue from the inside.
- 4. Remove the end of the PTO shaft and store inside.
- 5. Touch up all paint nicks and scratches to prevent rusting.
- 6. Move to storage area.
- 7. Select an area that is dry, level and free of debris.
- 8. Unhook from tractor (see Section 3.6).

9. If the machine cannot be placed inside, cover with a waterproof tarpaulin and tie securely in place.
10. Store the machine in an area away from human activity. Do not allow children to play on or around the store machine.

Chapter 4. SERVICE AND MAINTENANCE

4.1 SERVICE

4.1.1 FLUIDS AND LUBRICANTS

1. Grease:

Use an SAE multi-purpose high temperature grease with extreme pressure (EP) performance. Also acceptable is an SAE multi-purpose lithium base grease.

2. Gear Box Oil:

Use Shell Alvania 00 gear lube or 85W140 or 140 wt. or equivalent for all operating conditions.

Each Gear BOX Capacity: 0.85 liter

3. Storing Lubricants:

Your machine can operate at top efficiency only if clean lubricants are used. Use clean containers to handle all lubricants. Store them in an area protected from dust, moisture and other contaminants.

4.1.2 GREASING

Use the Maintenance Checklist provided to keep a record of all scheduled maintenance.

1. Use a hand-held grease gun for all greasing.
2. Wipe grease fitting with a clean cloth before greasing, to avoid injecting dirt and grit.
3. Replace and repair broken fitting immediately.
4. If fittings will not take grease, remove and clean thoroughly. Also clean lubricant passageway. Replace fitting if necessary.

4.1.3 SERVICING INTERVALS

The period recommended is based on normal operating conditions. Severe or unusual conditions may require more frequent lubrication or oil changes.

8 Hours or Daily

1. Lubricate PTO driveline (2 locations).
2. Pull PTO driveline apart. Grease the telescoping components.
3. Lubricate castor shaft.
4. Lubricate tail wheel.

40 Hours or Weekly

Check gear box oil levels. Add as required.

Annually

1. Wash machine.
2. Disassemble PTO driveline. Clear and lubricate PTO components and driveline guard.

4.1.4 SERVICE RECORD

See Lubrication and Maintenance sections for details of service. Copy this page to continue record.

8 Hours or Daily													
Lubricate PTO Driveline													
Lubricate													
Lubricate													
Lubricate													
40 Hours or Weekly													
Check Gear Box Oil Level													
Annually													
Clean Machine													
Lubricate and Clean PTO Driveline Guard													

4.2 MAINTENANCE

By following a careful service and maintenance program for your machine, you will enjoy many years of trouble-free operation.

4.2.1 BLADE REPLACEMENT

A blade may become bent, chipped or broken when using and have to be replaced.

When replacing a blade, follow this procedure:

1. Raise the machine above the ground to provide access to the blades.
2. Stop engine, set park brake, remove ignition key and wait for all moving parts to stop before dismounting.
3. Support the machine with large blocks or safety stands.
4. Remove the nut through the access hole.
5. Push or tap the blade pin down.
6. Remove the old blade and replace with a new one
7. Tap or drive the blade bolt back into position.
8. Tighten the mounting bolt to its specified torque.

4.2.2 DRIVELINE MAINTENANCE

The PTO driveline is designed to telescope to allow for dimensional changes as the machine goes through its operating range. A tubular guard encloses the driving components and is designed to turn relative to the driving components. The driveline should telescope easily and the guard turn freely on the shaft at all times. Annual disassembly, cleaning and lubrication is recommended to insure that all components function as intended. To maintain the deiveline, follow this procedure:

1. Remove the driveline from the machine.
2. Pull driveline apart.
3. Use a screwdriver to pry the tabs out of the sleeves on each end. There are 3 tabs per guard.
4. Pull the shaft out of the plastic tubular guard.
5. Use a solvent to clean the male and female portions of the telescoping ends.
6. Apply a light coat of grease to each end.
7. Use a solve to wash the grooves on each end where the tabs are located. Clean each tab also.
8. Apply a light coat of grease to each groove.
9. Insert the shaft into its respective guard and align the slots with the groove.

10. Insert the tabs through the slots and seat in the groove.
11. Check that each guard turns freely on the shaft.
12. Assemble the driveline.
13. Check that the driveline telescopes easily.
14. Replace any components that are damaged or worn.
15. Install the driveline on the machine.

4.2.3 GEARBOX MAINTANCE

The heavy duty gearbox used on the Slasher will give many years of trouble-free service with minimal maintenance requirements. Maintain the gearbox by following this procedure:

1. Oil level:
 - a. Remove the level plug from the front of the gearbox.
 - b. The oil should just fill a few of the threads.
 - c. Add through the fill plug if required.

IMPORTANT: Check the oil level only when the unit is cold and the machine is on the level.

2. Repair:

When the gearbox noise level builds-up, it will be necessary to replace worn components or the entire gearbox depending on the condition.

The following items must be noted:

- a. Bottom bearing cap bolt torque 85 to 95 ft-lbs.
- b. Top bearing cap bolt torque 40 to 50 ft-lbs.
- c. Gear backlash 0.006 to 0.018 inches at 2-13/16 inches from input shaft centerline.
- d. Gearbox output shaft bearing pre-load should result in 3/16 inlbs. Turning torque. Vary the number and thickness of shims when assembling to change the bearing pre-load.

Chapter 5. TROUBLE SHOOTING

This Slasher is designed to cut grass or other plants. It is a simple and reliable system that requires minimal maintenance.

In the following section, we have listed many of the problems, causes and solutions to the problems that you may encounter.

Problem & Possible Cause	Solution
1. Cutter doesn't turn PTO shaft slips	Repair tractor PTO clutch
2. Poor cutting job Traveling too fast. Blades dull. Grooves in grass. Scalping. Grass being left.	Slow down. Sharpen blades. Bent blade. Straighten or replace blade. Machine too low. Raise machine. Traveling too fast. Slow down. Top link too short. Extend top link.
3. Gearbox seal leaking Gears overheating.	Drill 3/16" hole in level plug and insert cotter pin. Hole will act as a breather and prevent pressurizing.
4. Noisy gearbox Poor gear mesh.	Remove input shaft and gear. Replace worn parts. Reassemble and use shims to give a gear backldash of 0.006-0.018 inches measured at 2 13/16" from shaft centerline.
5. Clutch slips	

Overloads. Clutch. Clutch worn out. 6. Vibration Out of balance.	Slow travel speed. Tighten springs on clutch plates. Replace clutch components or assembly as required. Check for bent, damaged or broken blades. Repair or replace as required
---	--

Chapter 6. ASSEMBLY

The machine is shipped from the factory in a partially disassembled form that allows for easy and convenient shipping.

When preparing for the customer, follow this procedure:

1. Place the machine to the ground slow. Remove the mounting frame, pins and driveline from the frame and lay to the side.
2. Install and secure the wheel **anchor assembly to the rear crossbar. Tighten clamping bolts to their specified torque.**
3. Install the PTO driveline
 - a. Remove the bolts from the input yoke.
 - b. Attach driveline to yoke.
 - c. Tighten mounting bolts to their specified torque.
4. Attach 3 point hitch A frame to the front of the machine. Be sure to position 3 point mounting pin to the front.
5. Add a quart of the specified oil to the gearbox. Tighten fill plug.
6. The machine is now read to attach to your tractor.

Chapter 7. SPECIFICATIONS

7.1 MECHANICAL

MODEL	TM110	TM1350	TM140	TM160	TM180
DEMENSIONS (L×W×H)	1100×1100× 900mm	1350×1350× 900mm	1400×1400× 900mm	1600×1600× 900mm	1700×1700× 900mm
STRUCTURE WEIGHT	135kg	155kg	160kg	220kg	230kg
CUTTING WIDTH	1340mm	1340mm	1340mm	1540mm	1640mm
WORKING EFFICIENCY	20000~40000 m ² /h	25000~45000 m ² /h	30000~50000 m ² /h	30000~55000 m ² /h	40000~60000 m ² /h
INPUT TURNNING SPEED	540r/min	540r/min	540r/min	540r/min	540r/min
PTO SPLINE	6×6×850	6×6×850	6×6×850	6×6×850	6×6×850
PWER REQUIRED	20~30hp	20~35hp	20~35hp	25~40hp	30~50hp

7.2 BOLT TORQUE

CHECKING BOLT TORQUE

The tables shown below give correct torque values for various bolts and nuts. Tighten all bolts to the torques specified in chart unless otherwise noted. Check tightness of bolts periodically, using bolt torque chart as a guide. Replace hardware with the same strength bolt.

Tightening Torque Table of Main Bolts and Nuts

Seq. No.	Location/Designation	Specifications	Tightening torque (N. m)	Intensity grade
1	Gearbox and Deck/ bolts	M16×45	~	8.8
2	Gearbox / bolts	M10×30	~	8.8
3	Gearbox / bolts	M8×25	~	
4	Frame and Deck / bolts	M14×25	~	8.8
5	Blades/nuts	M14	~	8.8

Chapter 8. PARTS LIST

The manual contains a parts list for your machine. It is divided into major sections which correspond to the groups shown in the Table of Contents and the accompanying illustration.

The first page of each major section lists the contents of that section, each of which consists of exploded views and related tabular listings.

When ordering parts, always give your dealer the Model of your machine to assist him in ordering and obtaining the correct parts. Use the exploded view and tabular listing of the area of interest to exactly identify the required part.

8.1 TOPPING MOWER ASSEMBLY

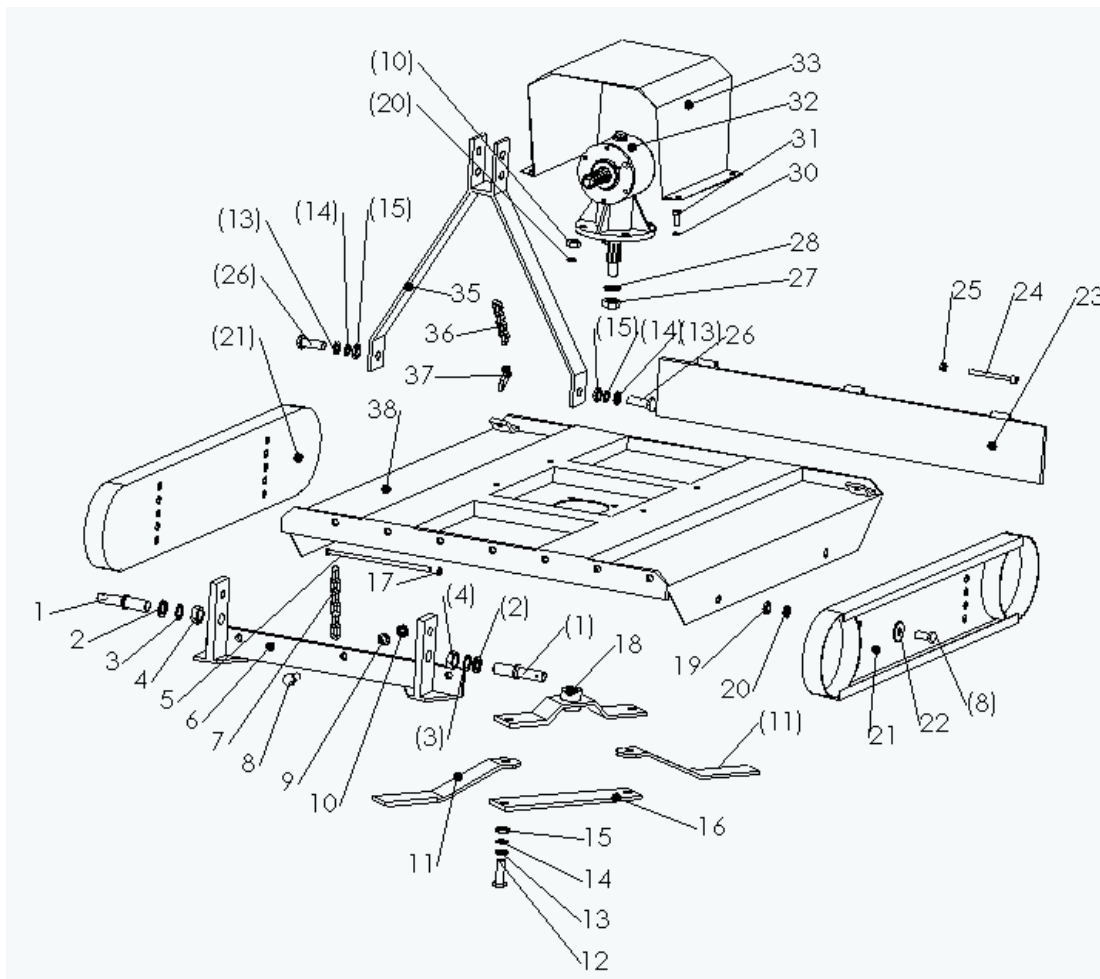

Topping Mower Assembly

Ser.No	Part No	Name & Specification	Quantity	Remarks
1	SL110.120	Pin	2	
2	GB97.1-85	Plain washier24	2	
3	GB93-87	spring washier24	2	
4	GB6170-86	Hex.nut M24	2	
5		Circle Steel	1	
6	SL110.108	Mounting bracket for		

		front supporting		
7		Link	3	
8	GB5783-86	Screw M16×50	5	
9	GB97.1-85	Plain washier16	3	
10	GB889-86	Lock nut M16	3	
11	.SL120.00.118	Blade	2	
12	SL110-133	Screw	2	
13	GB97.1-85	Plain washier18	6	
14	GB93-87	spring washier18	4	
15	GB6170-86	Hex.nut M18	4	
16	SL110-132	Supporting board for Blade	1	
17		Litter R pin	1	
18	SL110-131	Blade seat	1	
19	GB6170-86	Hex.nut M18	4	
20	GB97.1-85	Plain washier18	15	
21	SL110.109	Adjusting Board	2	
22	GB93-87	spring washier18	4	Bigger
23	SL110-121	Protecting plate	1	
24	GB70-85	Screw M10×110	2	
25	GB6170-86	Hex.nut M10	2	
26	GB5783-86	Screw M18×50	2	
27	GB 6178-86	Hex.nut M24	1	
28	GB6170-86	Plain washier24	1	
29	GB 91-86	Pin4 x 40	1	
30	GB93-87	Plain washier8	4	
	GB6170-86	Plain washier8	4	
31	GB5783-86	Screw M8×16	4	
32	SL140.00.012	Gearing Box	1	
33	SL110.109	Gearing Box Cover	1	
34	GB5783-86	Screw M16×45	4	
35	SL110.103	Front supporting	1	
36		Link ∅ 8	1	
37		Lock	2	
38	SL110.110	Deck	1	

The information contained in this operations manual is a general introduction only. The information contained herein may be modified at any time, for any reason. Modification may affect the details or specifications of the product described in this manual. Therefore, users – dealers must include the manufacturing date and serial number when placing an order for spare parts and components. Thanks.

